

# **PINBALL 2000 SCHEMATIC MANUAL**

***INCLUDING CABINET AND BACKBOX PARTS***

**Williams Electronics Games, Inc.  
3401 North California Avenue  
Chicago, IL 60618**

## TABLE OF CONTENTS

CABINET AND BACKBOX PARTS.....	1
POWER WIRING.....	2
AUDIO AMP SCHEMATIC.....	4
PRISM ROM DAUGHTER SCHEMATIC.....	5
PRISM MAIN SCHEMATIC.....	6
POWER DRIVER SCHEMATIC.....	9

<u>Item</u>	<u>Part Number</u>	<u>Description</u>
1	04-12480.4	Cabinet
2	01-11400-1	Leg Mounting Bracket (x4)
3	A-19514-6	Leg Assembly – Black Ridge (x4)
4	08-7377	Leg Leveler/Adjuster (x4)
5	01-15132-1	Playfield Slide Track – Right
6	04-12610	Stay Arm
7	A-22996	Lockdown Bracket Assembly
8	5555-16059-00	Speaker, 6.5" Woofer, 4c
9	A-22966	Power Control Box Assembly
10	04-12596.1	Drip Plate
11	5610-15930-00	Transformer Assembly
12	A-22998	Driver Board Cover Assembly
13	01-15146	Driver Board Back Plate
14	04-12329	Power Driver Board PCB Assembly
15	03-10011	Cover Stop Tube
16	09-96012-33	Coin Door – USA
17	20-10690	Hand Molding Lock
18	A-22984	Flipper Button Assembly (x2)
19	See Game Manual	Push Button w/Switch
20	01-15184	Launch Button Bracket
21	See Game Manual	Push Button w/Switch
22	A-23024	Coin Door Interlock Switch Assembly
23	A-22964	Coin door Interface PCB Assembly & Spacer
24	A-17195-2	Tilt Switch Assembly w/Cable
25	04-10346.1	Tilt Mechanism Assembly
26	20-6502-A	Plumb Bob
27	A-23139	4-Ball Cash Box Assembly
28	A-22997	Hand Molding Assembly
29	A-22976-1	Side Molding Assembly (x2)
30	04-12739.1	Tinted Playfield Glass Assembly
31	03-8091	Rear Molding
32	01-15214	Hole Cover
33	01-15212	Cabinet Corner Bracket

**Miscellaneous Parts: (Not Shown)**

<u>Part Number</u>	<u>Description</u>
01-15132-2	Playfield Slide Track – Left
04-12628.2	Safety Pin Bracket
01-15136-1-2	Lock Plate
See Game Manual	Cordset
20-6500	Steel Ball, & 1 1/16" (x4)
01-6389-1	Cash Box lock Bracket

**Cabinet Cables:**

<u>Part Number</u>	<u>Description</u>
H-22740-2.1	Cabinet Cable
H-22740-1.2	Cabinet Cable
H-22736	Secondary Power Cable
See Game Manual	Cabinet Power/Speaker Cable
See Game Manual	Cabinet Switch/Lamp Cable

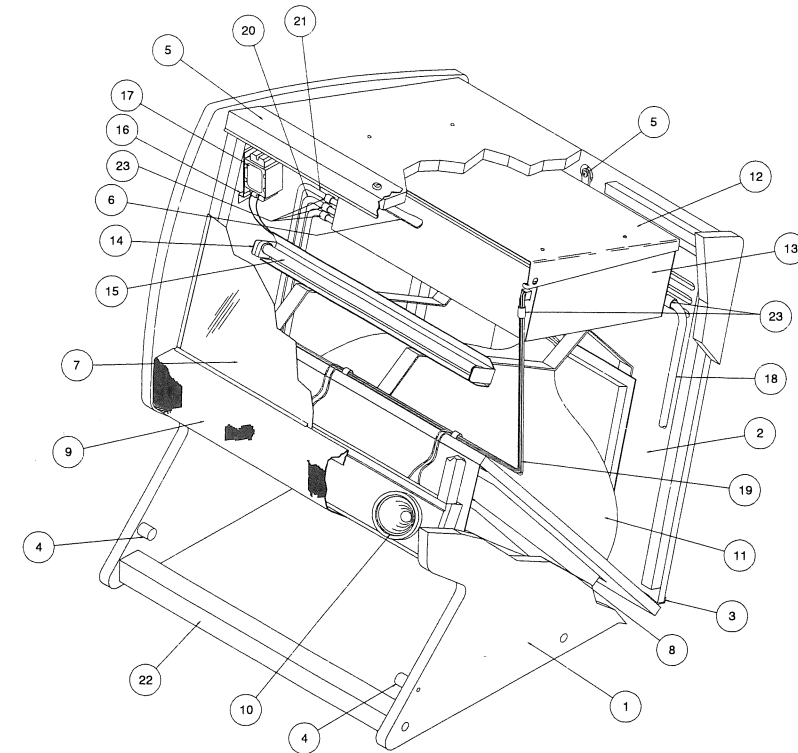
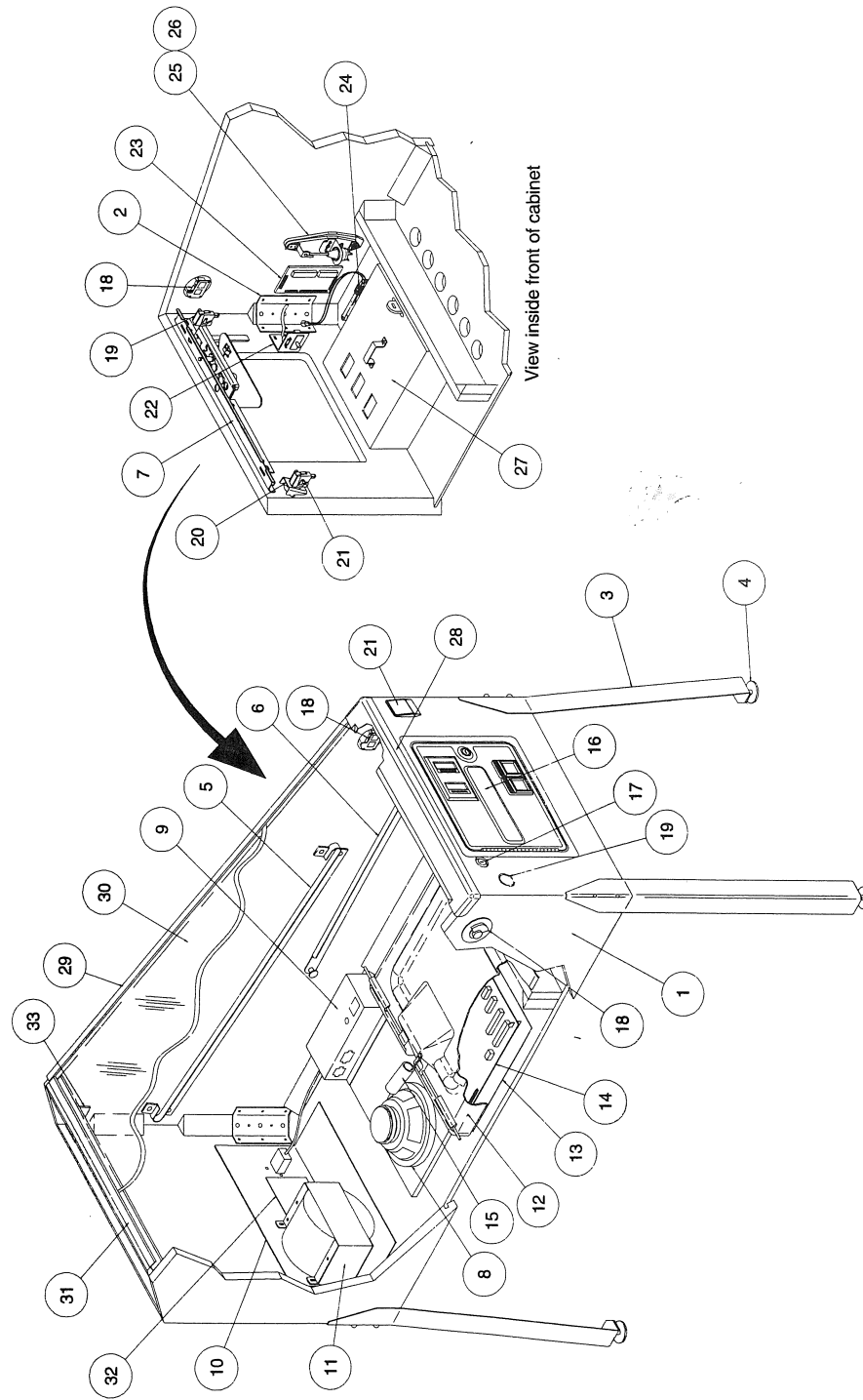

<u>Item</u>	<u>Part Number</u>	<u>Description</u>
1	04-12489.4	Back Box
2	A-22982	Back Boor Assembly
3	01-15131	Door Channel
4	03-9992	Knob
5	A-22981	Lock & Plate Assembly
6	01-15134	Front Lock Cam
7	A-22975-50070	Marquee Assembly
8	04-12607.1	Speaker Grill Bracket
9	01-12606.1	Speaker Grill
10	5555-15580-00	Speaker - 4c, 25W
11	5675-16058-01	Monitor – 19"
12	01-15130.1	Computer Case Mounting Bracket
13	See Game Manual	Computer Case Assembly
14	A-22980	Fluorescent Lamp Assembly

<u>Item</u>	<u>Part Number</u>	<u>Description</u>
15	24-8809	Fluorescent Lamp 15W, 18"
16	04-12752	Ballast Mounting Bracket
17	A-23155	Ballast Assembly
18	A-23160	CPU/AC Power Cable
19	H-22737-1	AC/Speaker Cable
20	20-10583	Extension Cable db09 – 10ft
21	20-10584	Extension Cable db25 – 10ft

**Miscellaneous Parts:**

<u>Item</u>	<u>Part Number</u>	<u>Description</u>
22	11-1464	Back Box Shipping Brace
23	5556-15272-00	Ferrite

NOTE: These part numbers are for reference only. Check the game manual for specific numbers.

For Japan

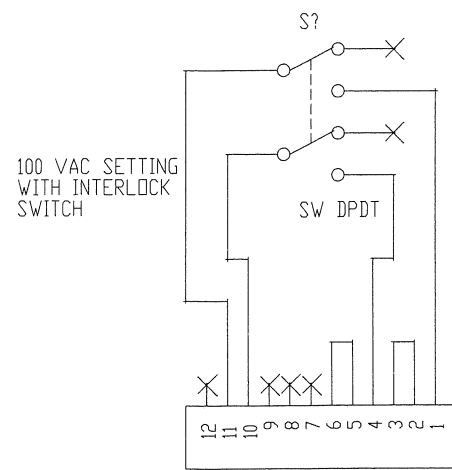

H-22990-3

For Domestic (low line)

100 VAC SETTING

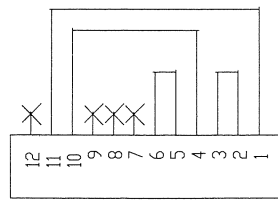

For Domestic

120 VAC SETTING

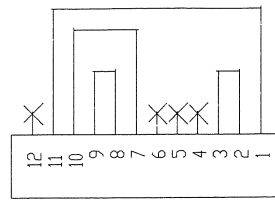

H-22990-1

For Europe (low line)

200 VAC SETTING

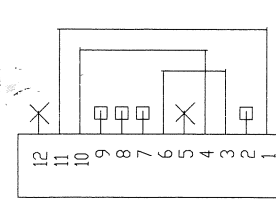

For Europe

220 VAC SETTING

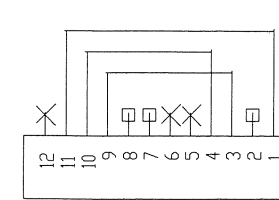

For Europe (high line)

240 VAC SETTING

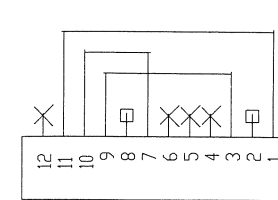

H-22990-2

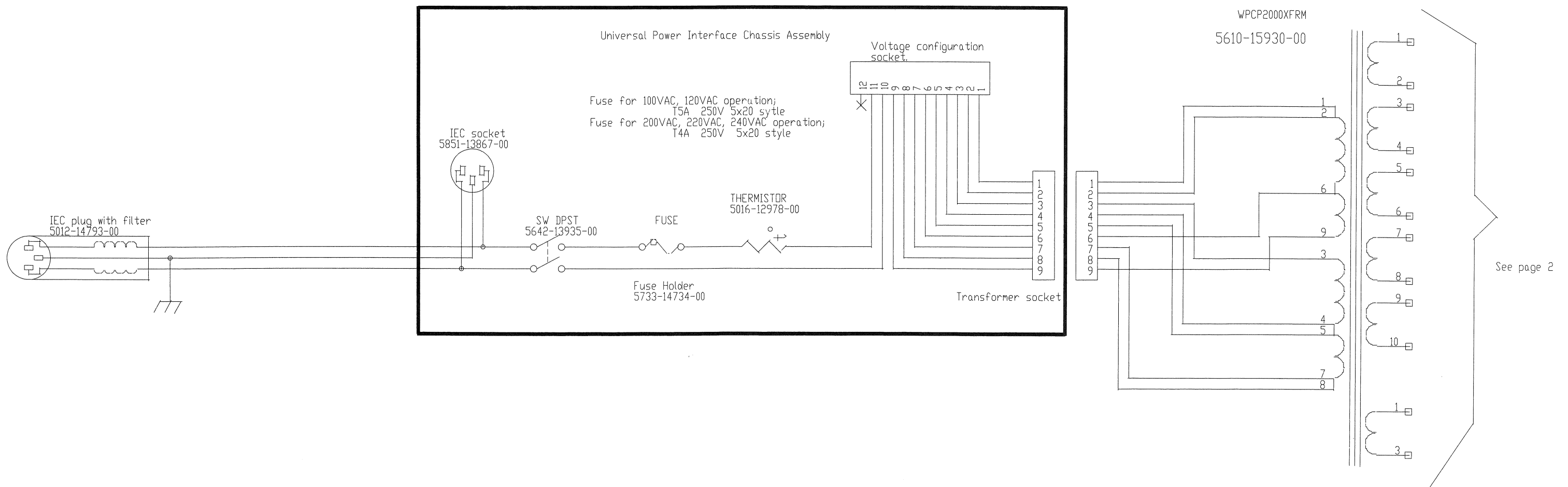

See page 1

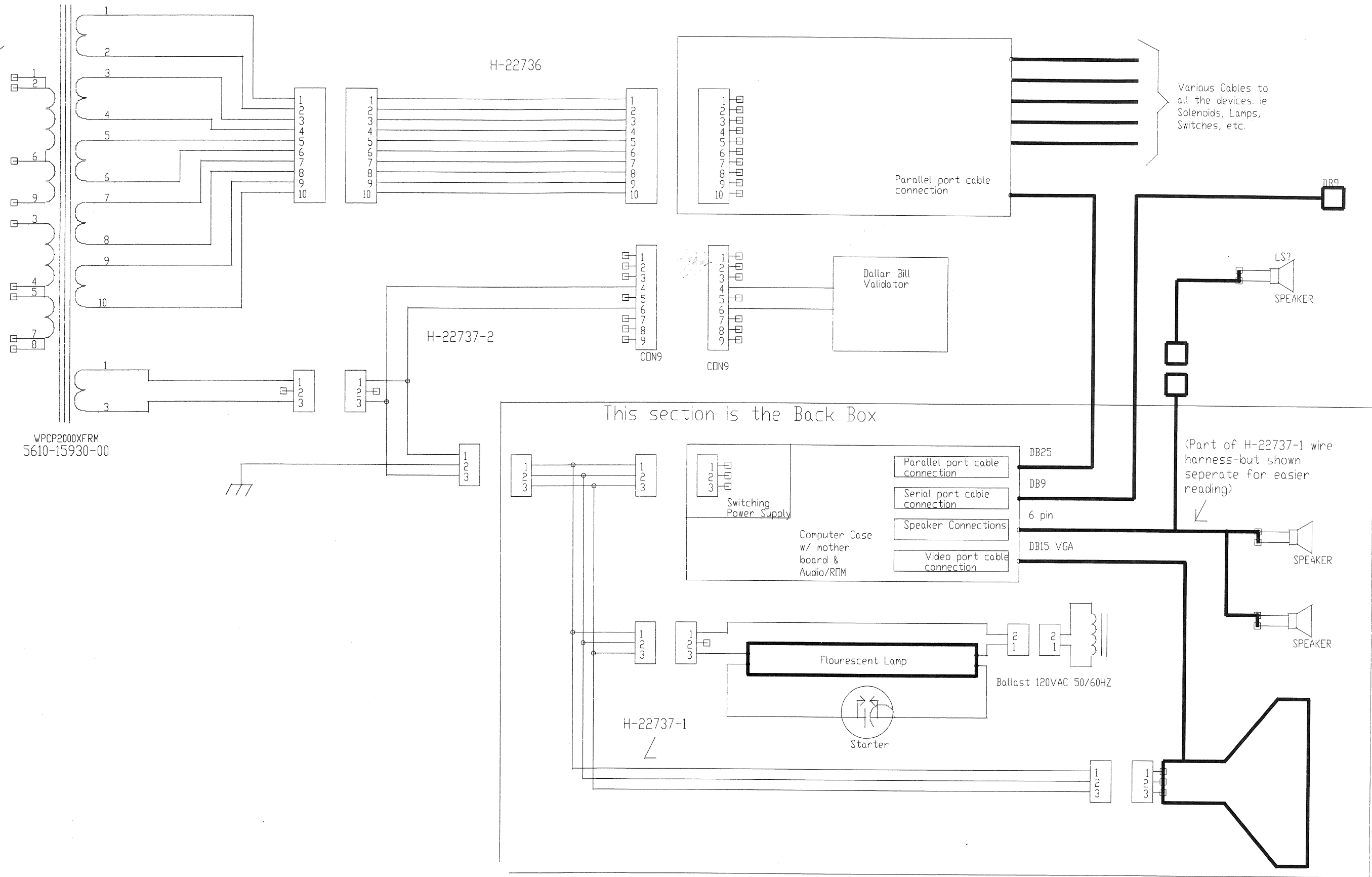

WPCP2000XFRM  
5610-15930-00

H-22736

H-22737-2

This section is the Back Box

H-22737-1

Various Cables to  
all the devices. ie  
Solenoids, Lamps,  
Switches, etc.

(Part of H-22737-1 wire  
harness-but shown  
separate for easier  
reading)

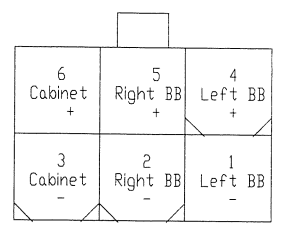
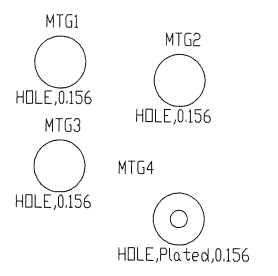
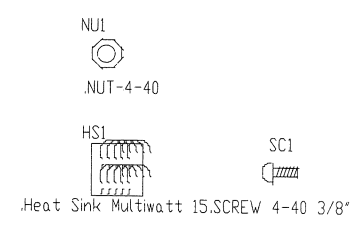
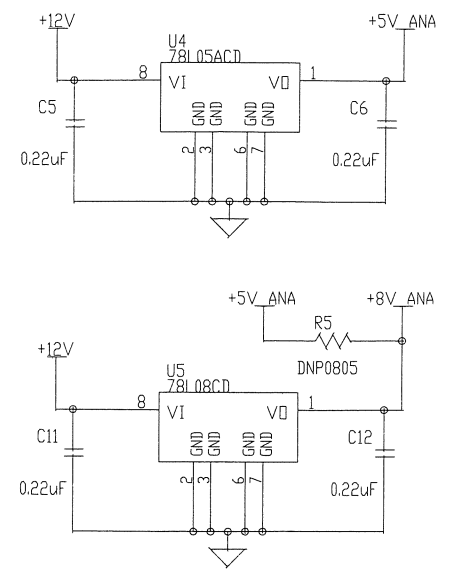
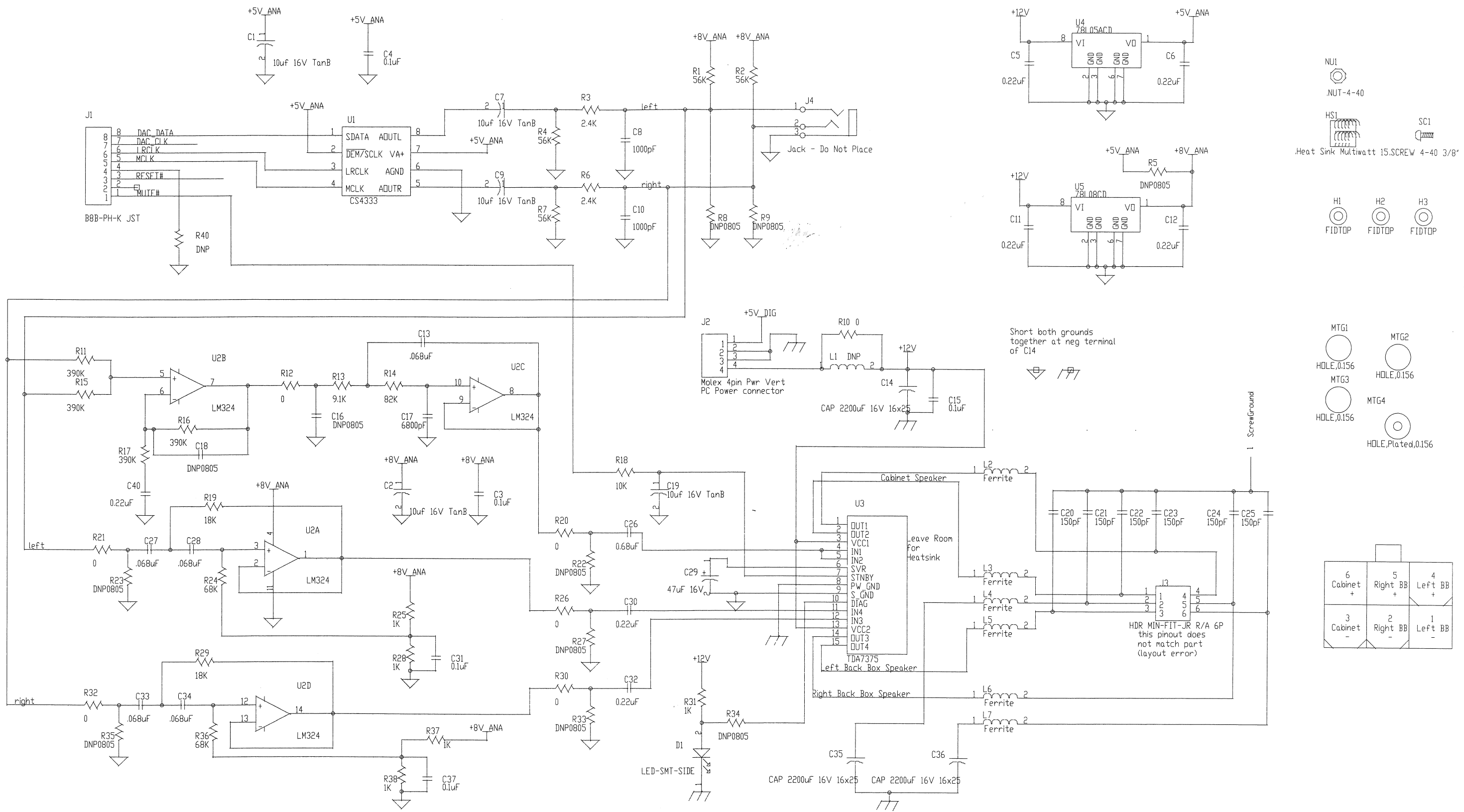

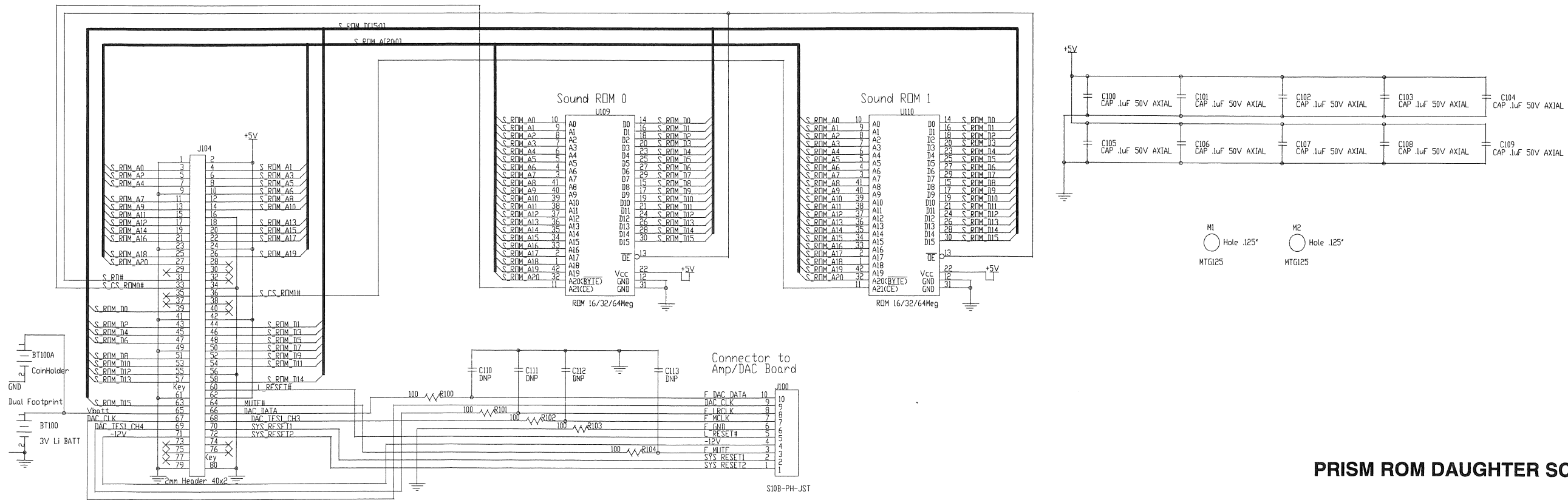
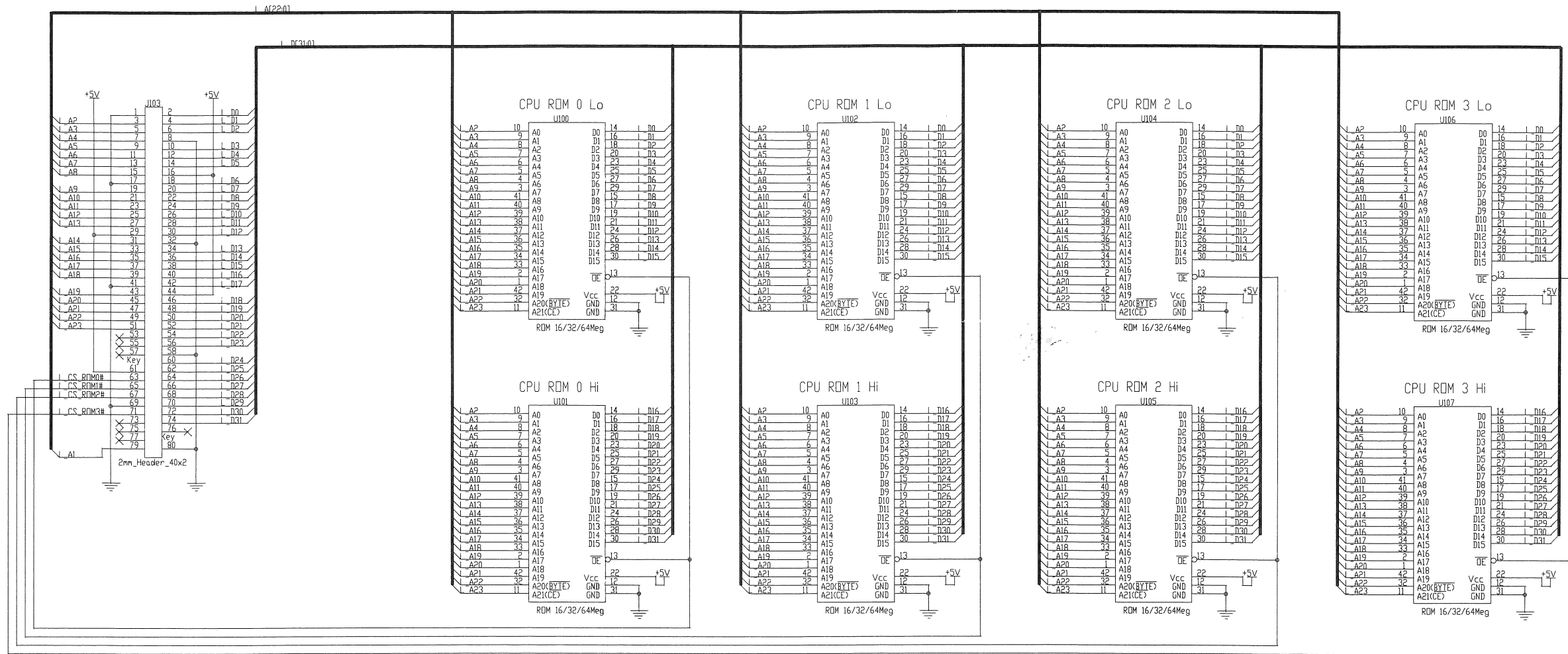

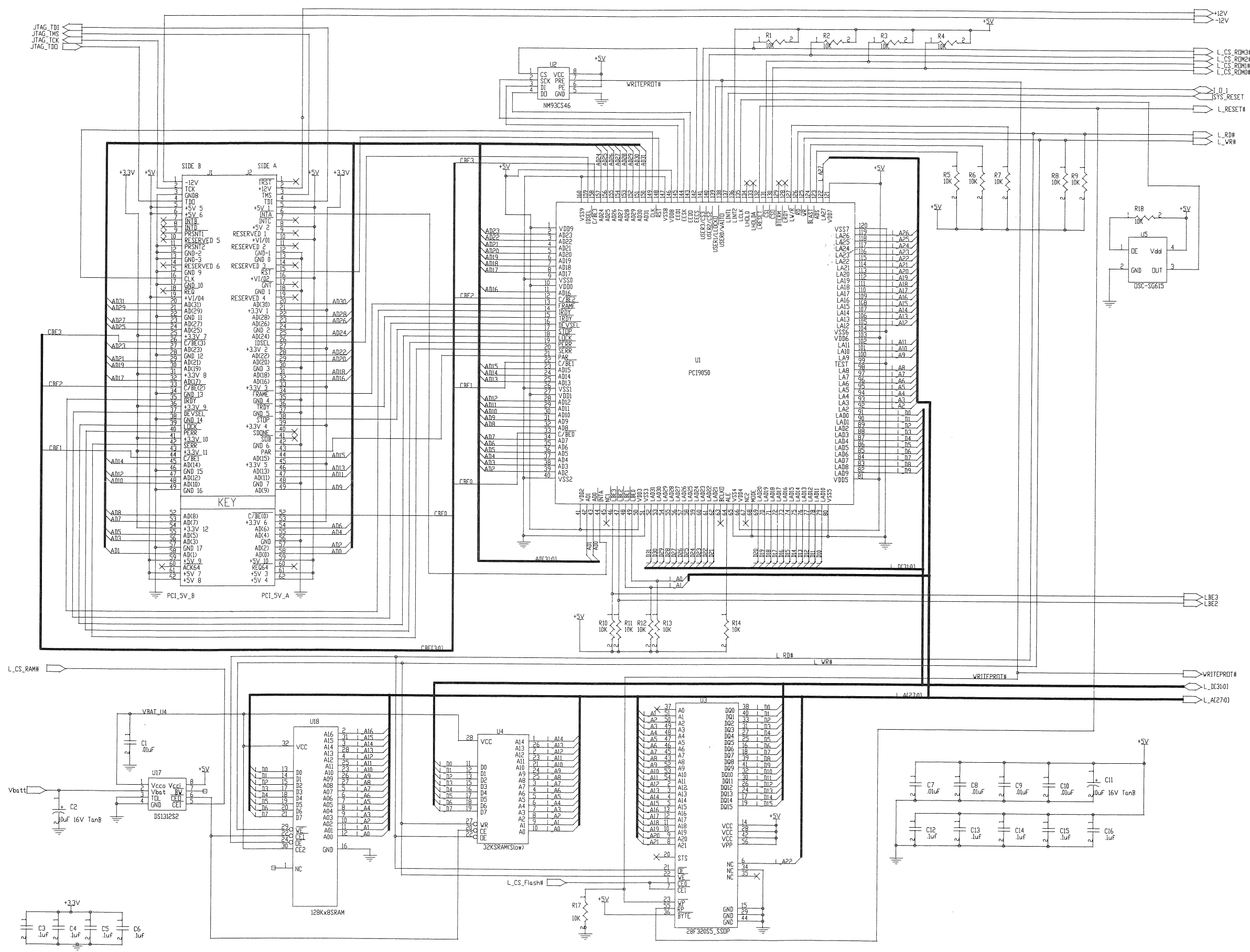



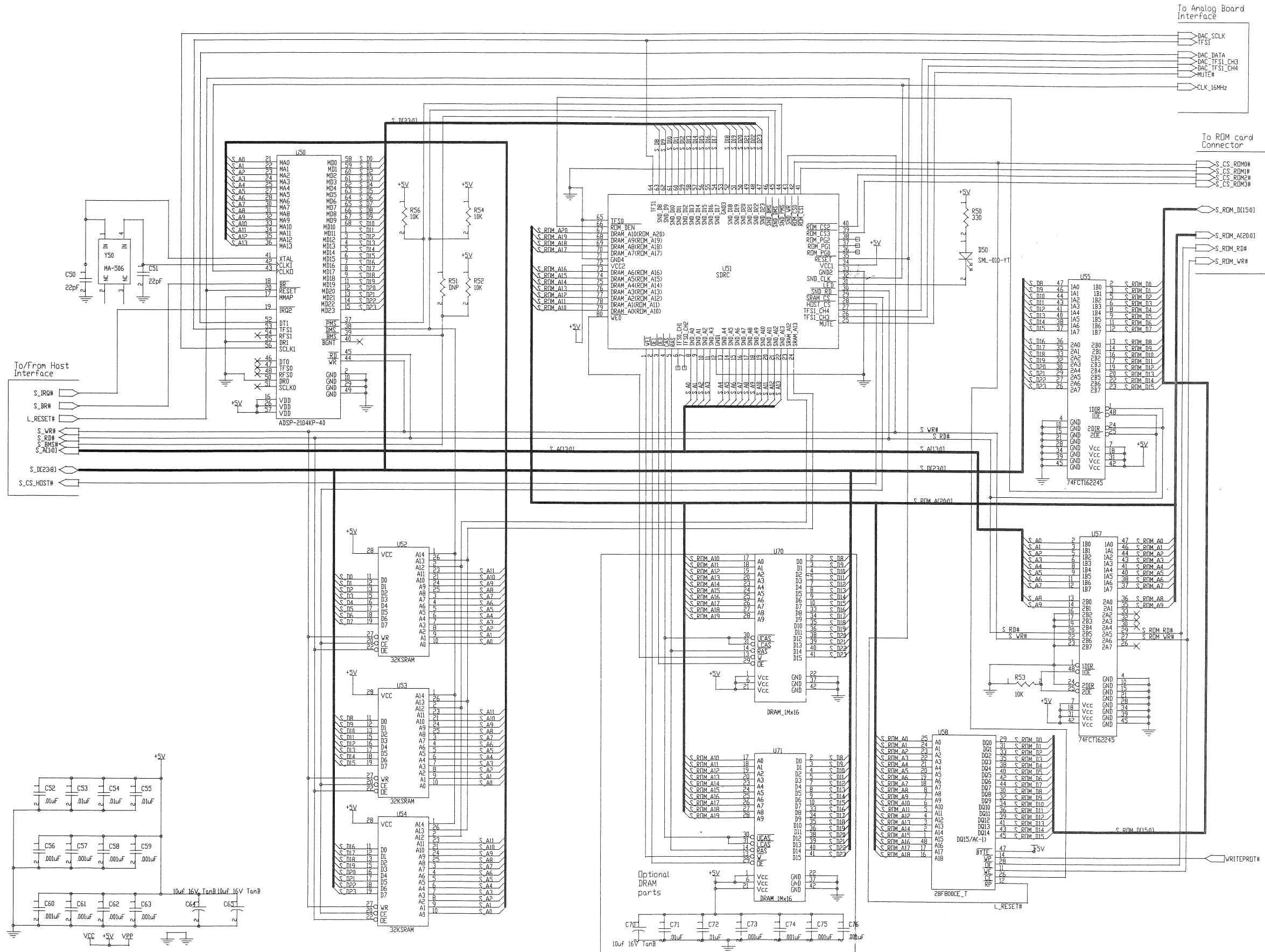

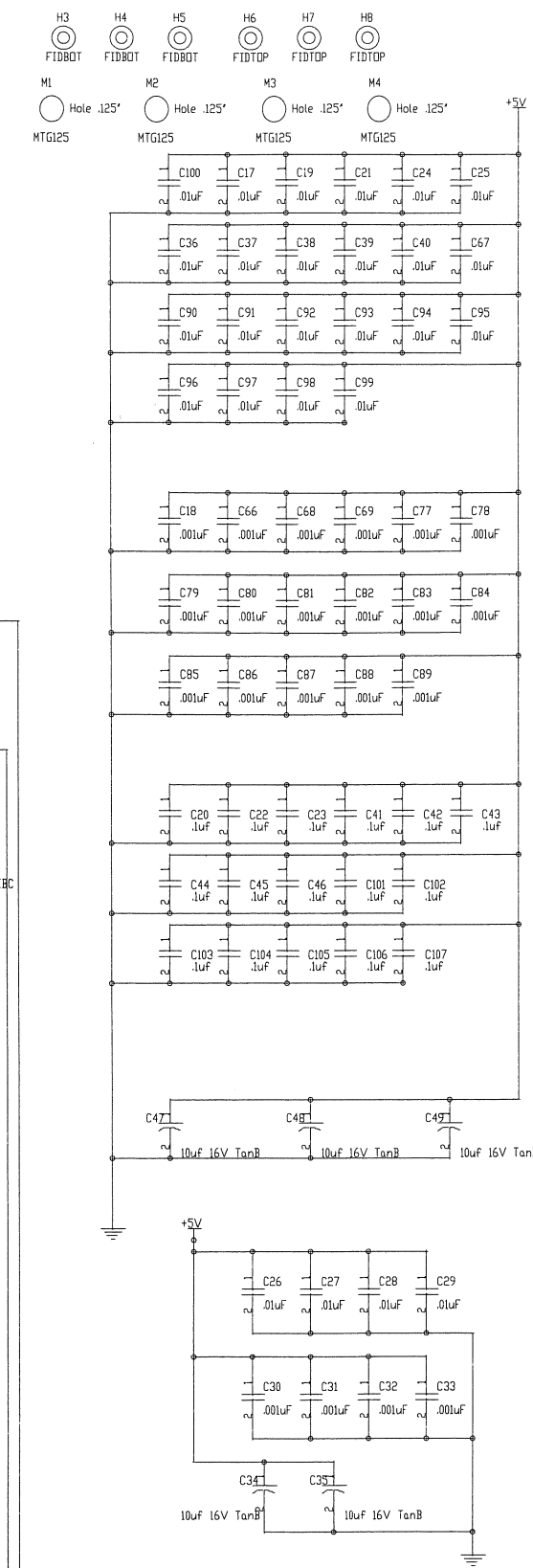
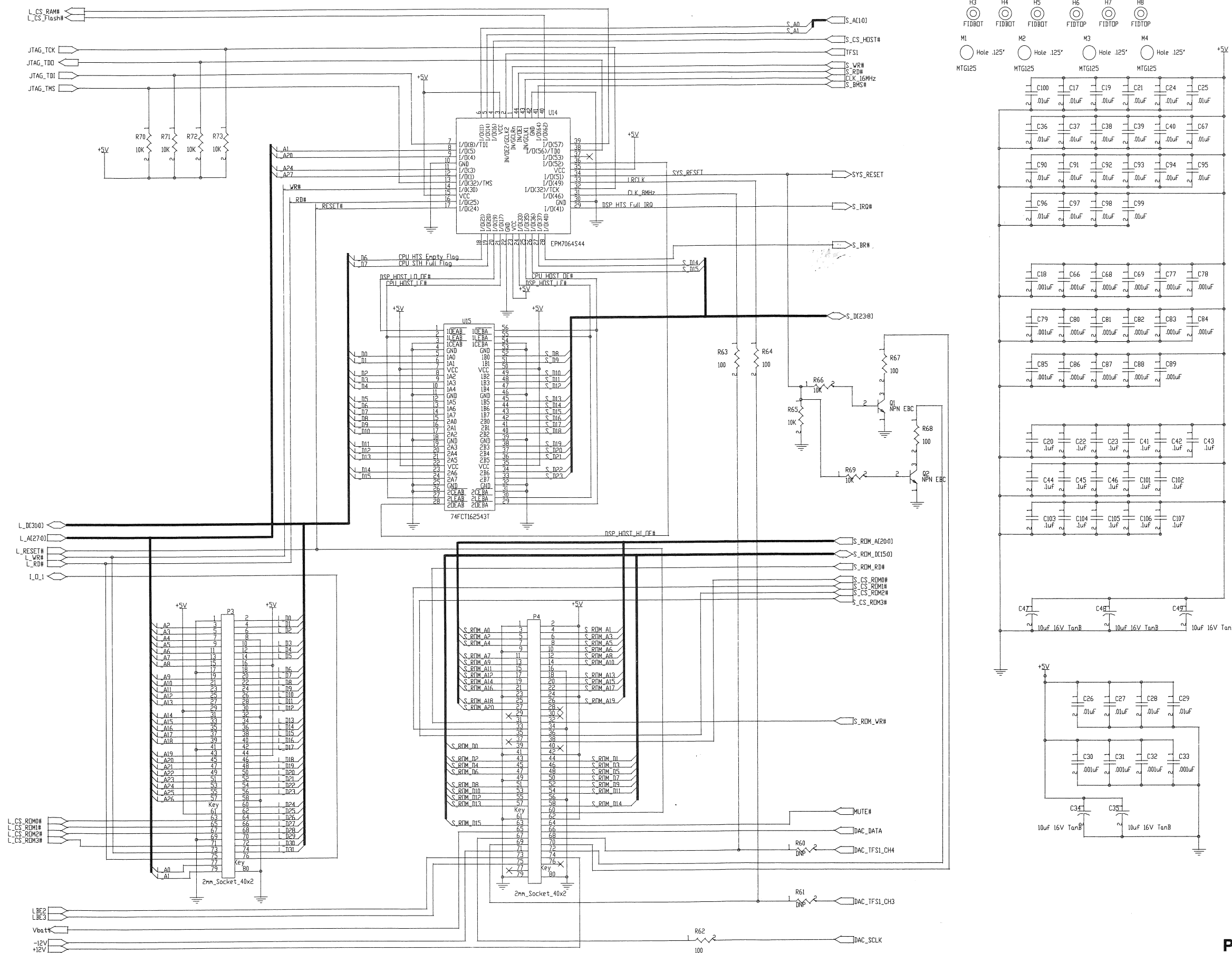



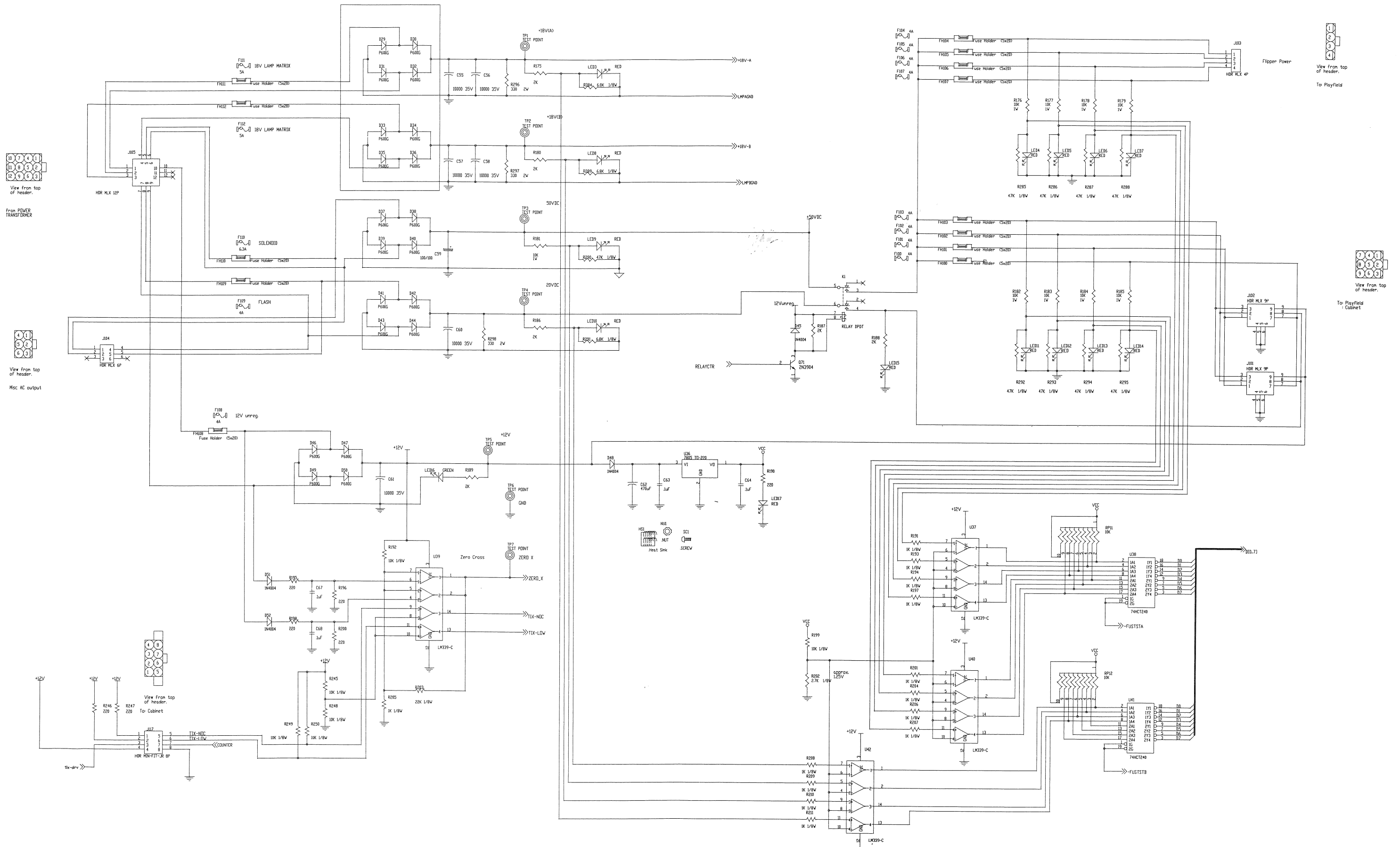

Option Dip Switches & System info

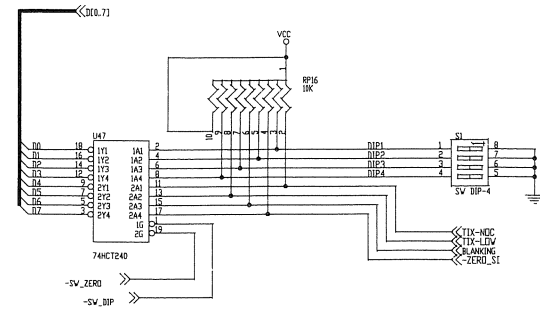

Coin Switch Receivers

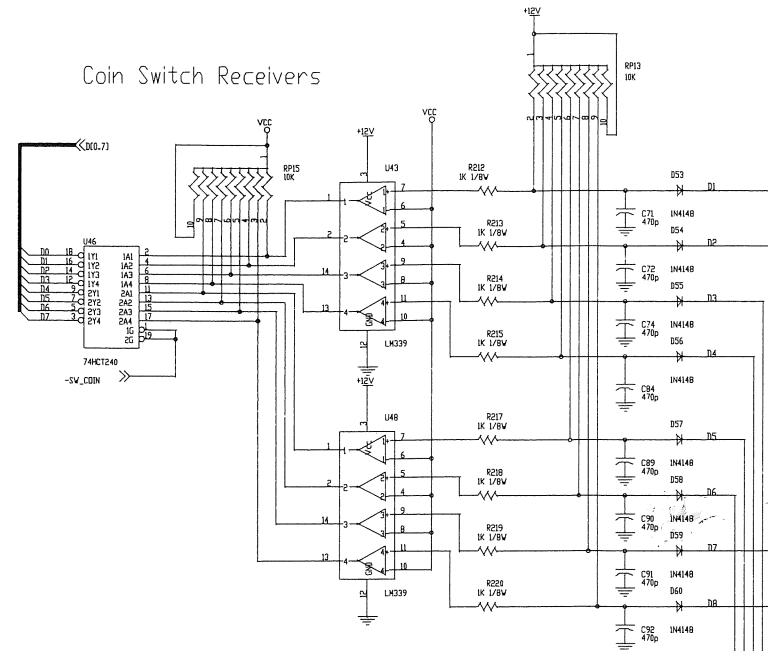

Switch Column Drives

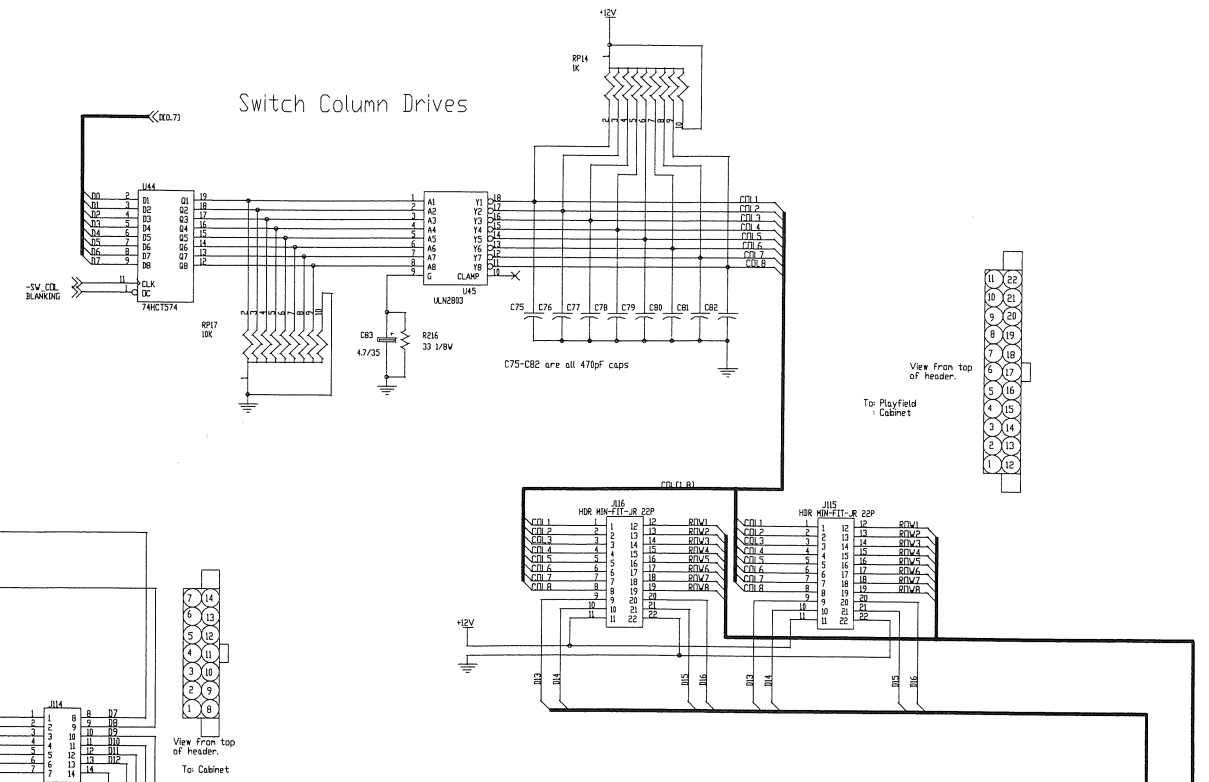

Flipper Switch Receivers

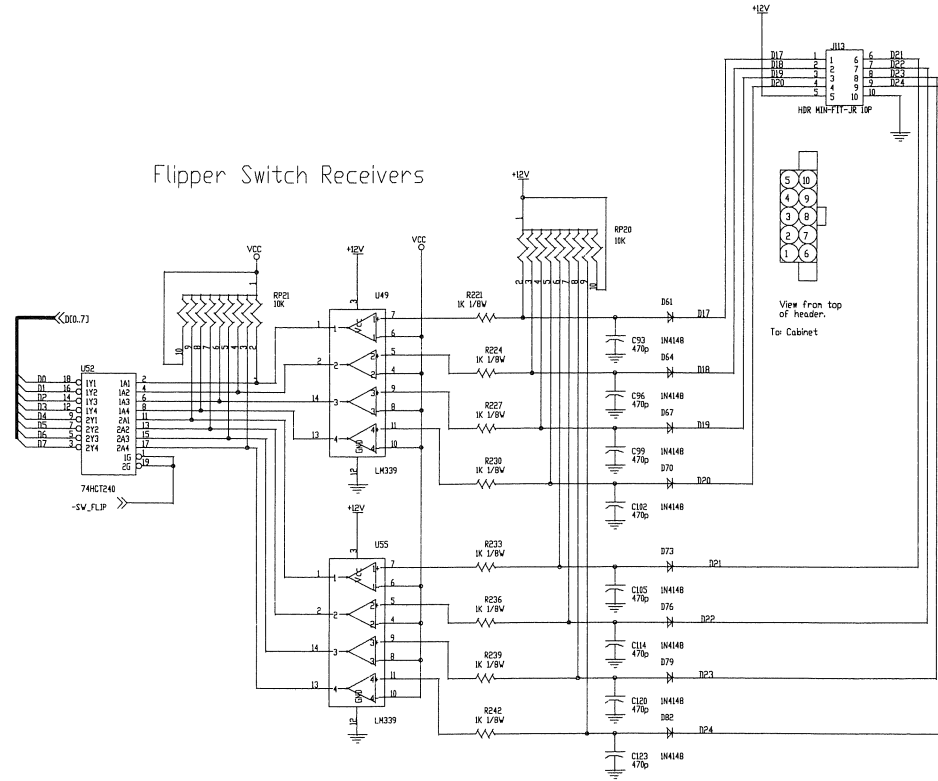

Flipper EDS & Diagnostic Switch Receivers

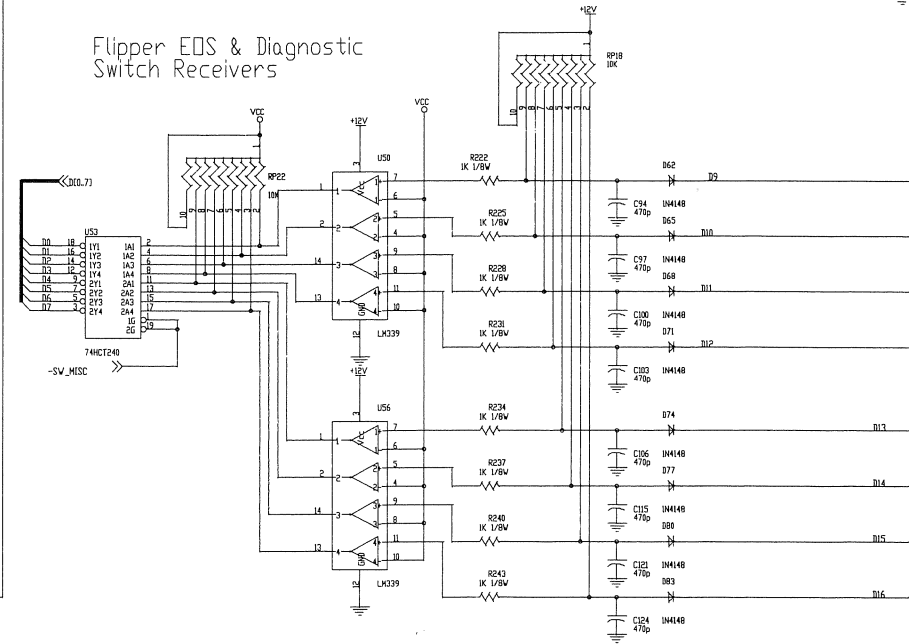

Switch Row Receivers

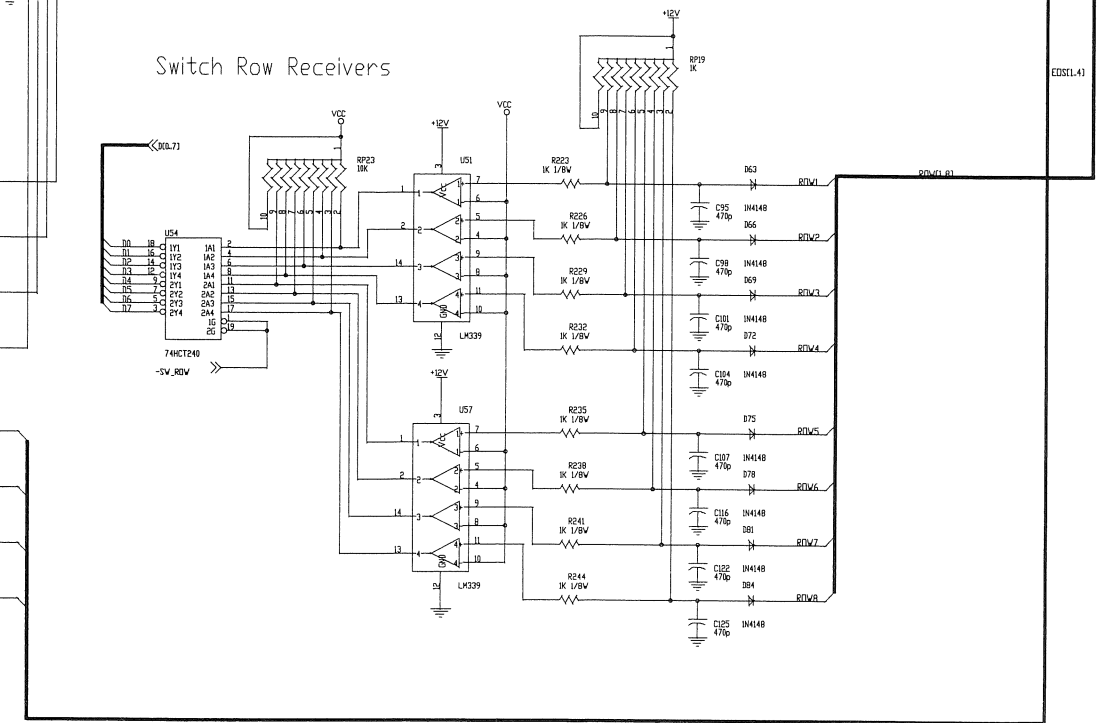

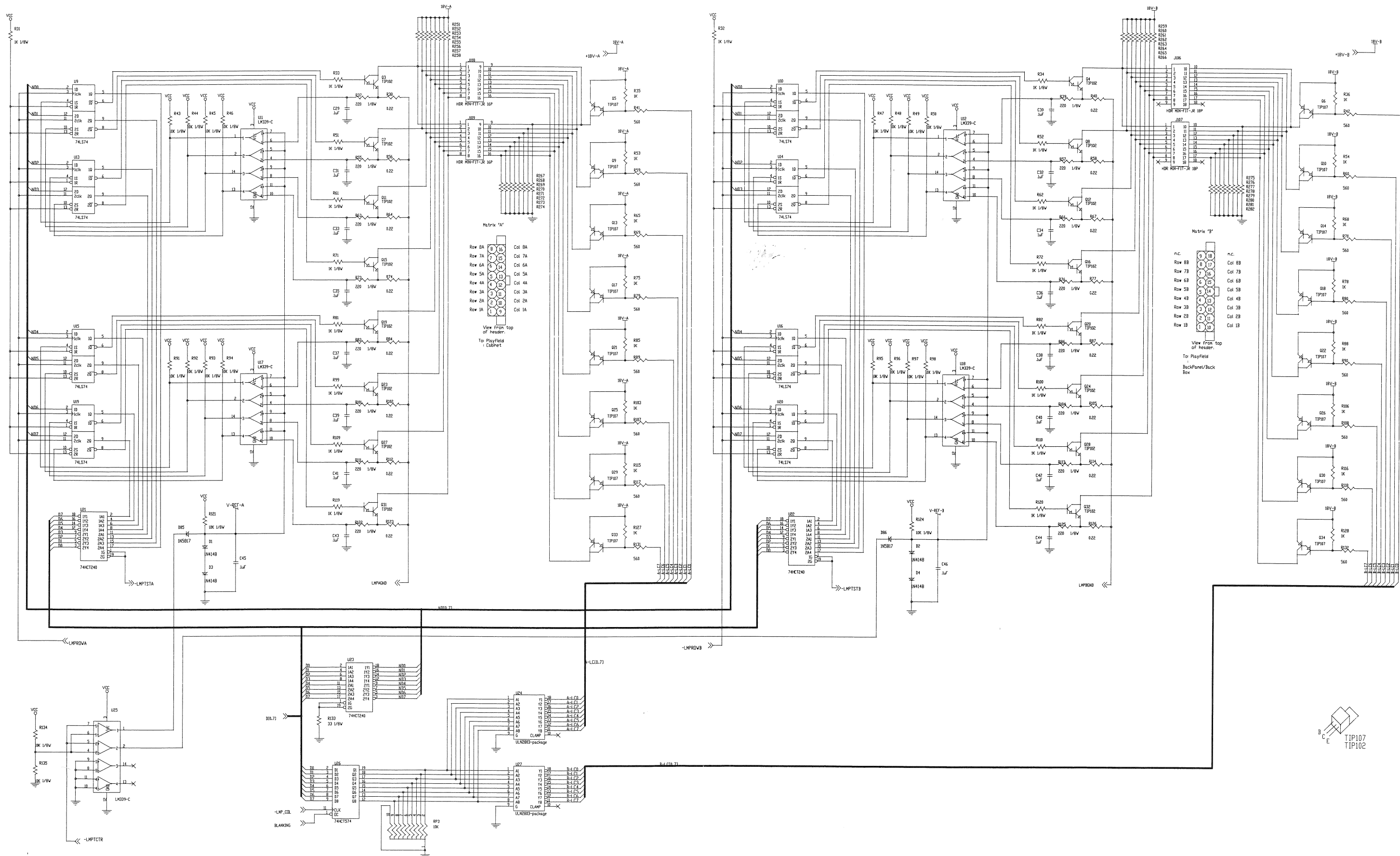

DRIVE BANK C

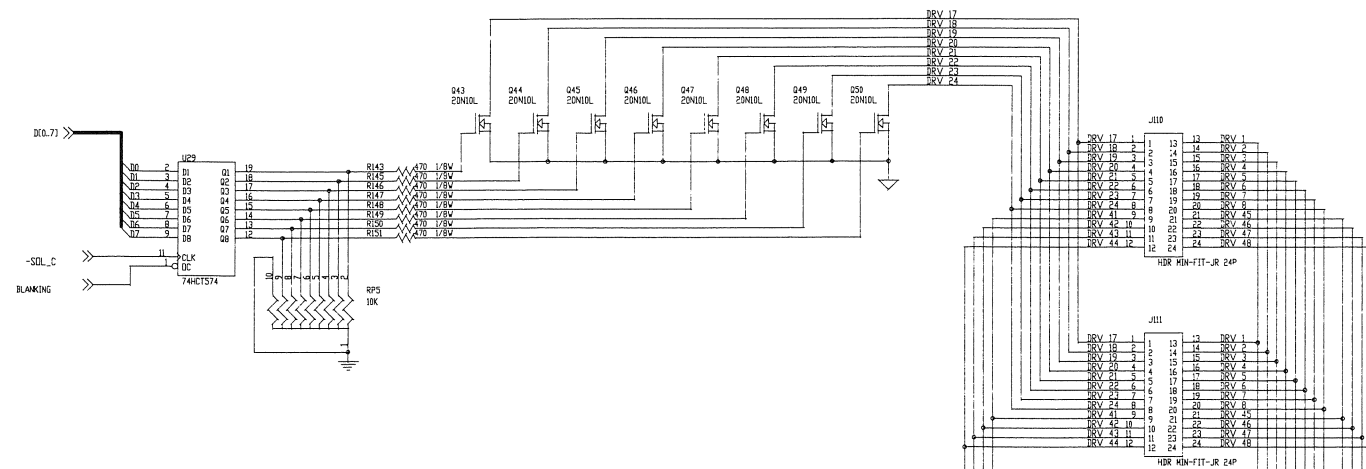

DRIVE BANK A

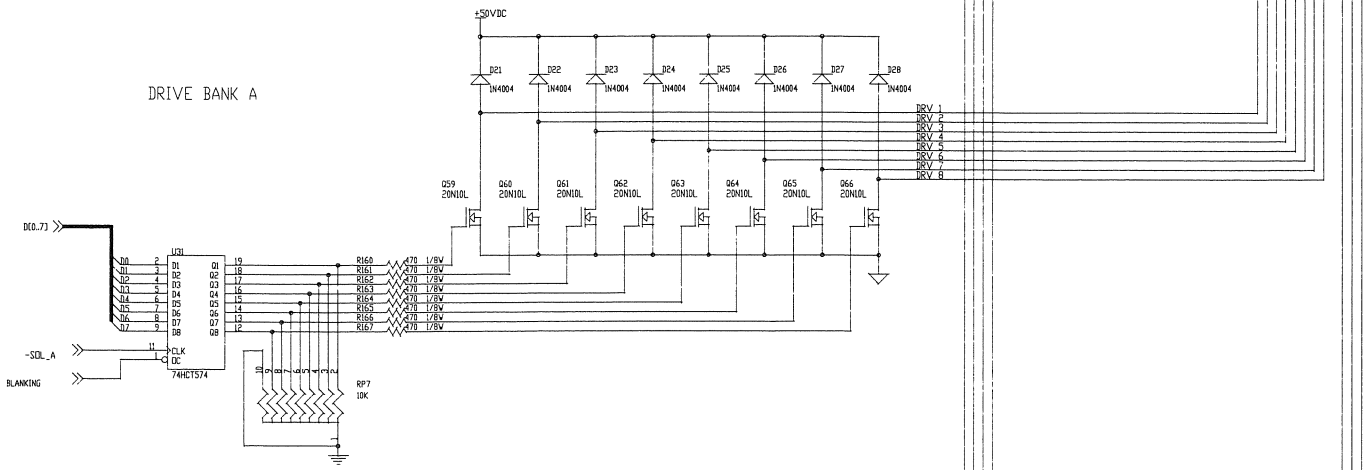

logic drivers

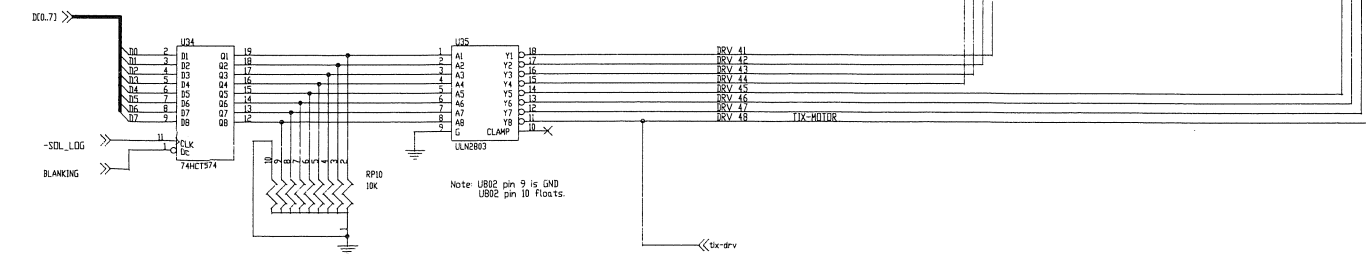

FLIPPER DRIVERS

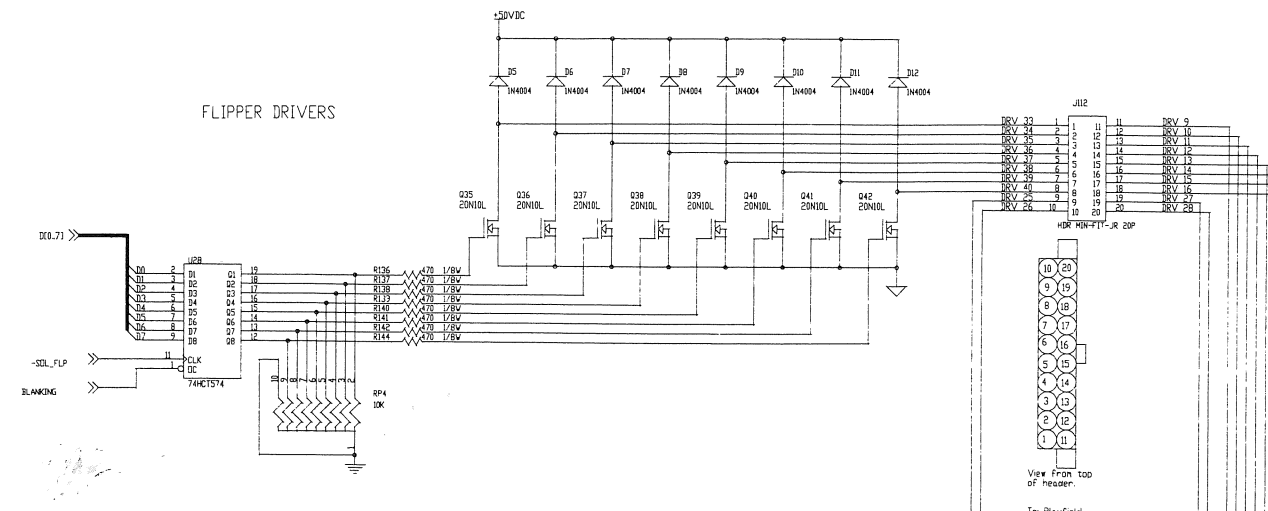

DRIVE BANK B

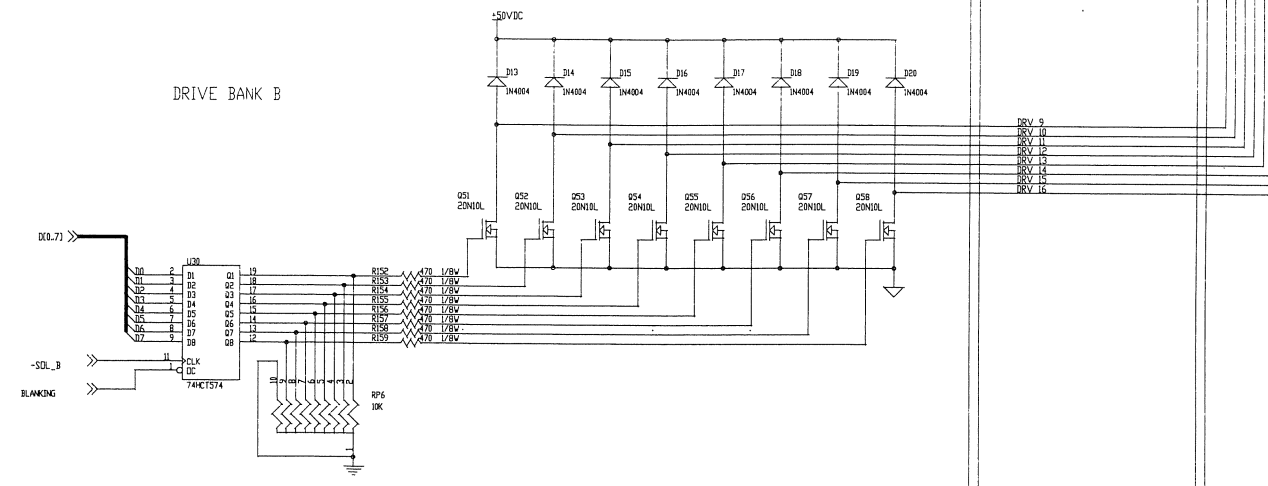

DRIVE BANK D

